



HME AHRENS-FOX PUMPER

CORE07



SPECIFICATIONS

- ◆ Chassis: SFO[†]
- ◆ MFDxl 12" Raised Roof
- ◆ Cummins L9 (380 HP / 1250 lb-ft)
- ◆ Hale Qmax (1500 GPM)
- ◆ 1000 Gallons
- ◆ Allison 3000EVS Transmission
- ◆ 24" Extended Front Bumper (Polished Stainless-steel)
- ◆ 18,740 lb. Front and 24,000 lb. Rear
- ◆ Ladders Through The Tank

PUMP MODULE

- ◆ Minimized linkage angles on the push/pull arms add durability and enable lower crosslays for ease of operation. The stainless-steel frame, plumbing and rubber isolators limit long-term wear and tear.

MANEUVERABILITY

- ◆ With a wheel-base of just over 14 ft., an overall length of 27.5 ft., and a 55-degree wheel cut, the SFO is nimble enough to serve as either a city truck or wildland.

[†] Prior generation chassis. CORE07 available on multiple custom chassis.

HME Ahrens-Fox
1950 Byron Center Ave SW
Wyoming, MI 49519
616.534.1463

FIRETRUCKS.COM



LEARN
MORE





HME AHRENS-FOX PUMPER

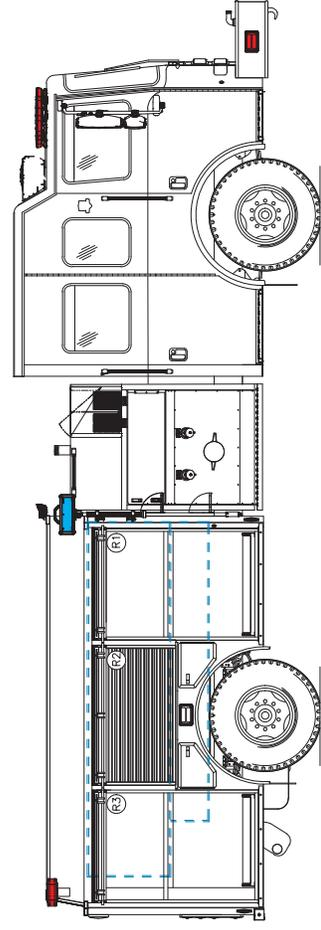
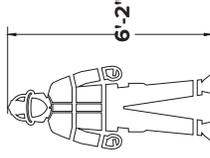
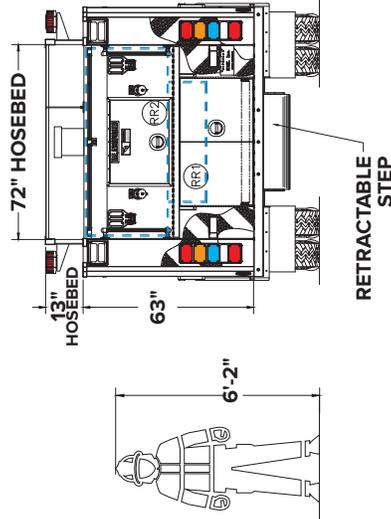
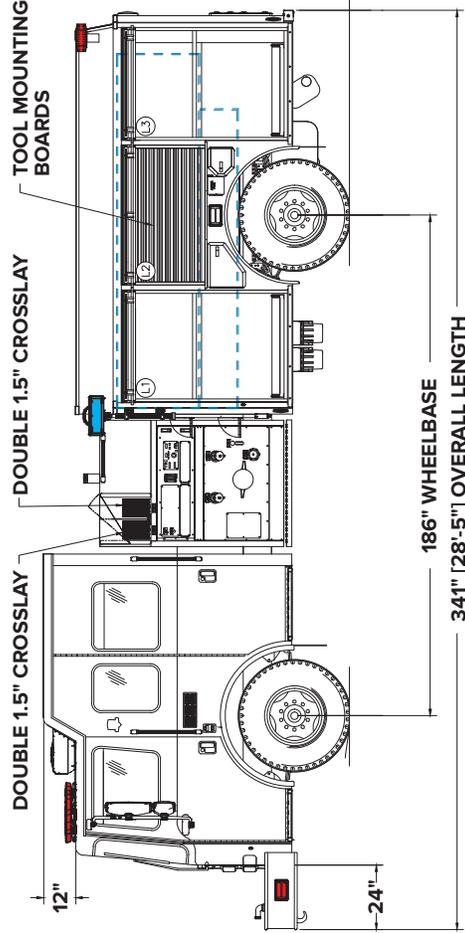
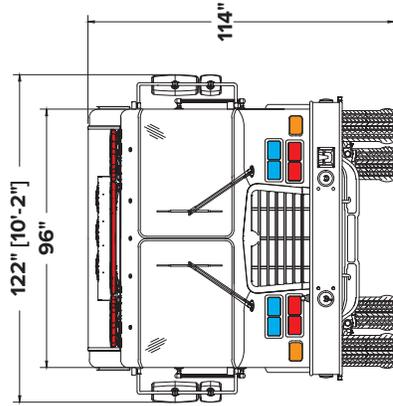
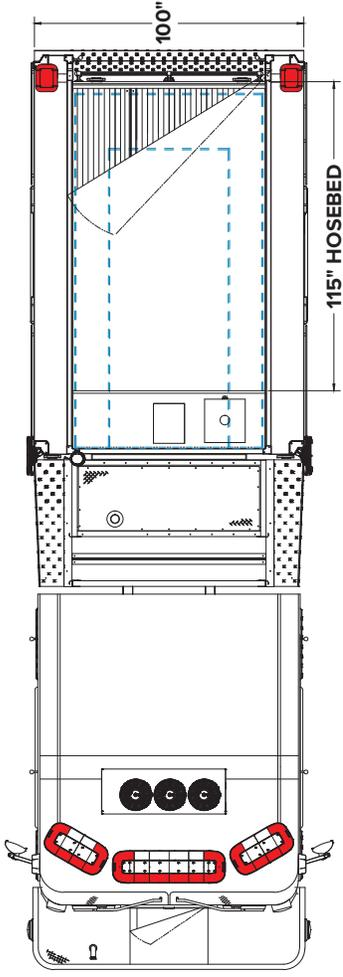

COMPARTMENTS			
LOCATION	DOOR FRAME OPENING	DEPTH	VOLUME (CUBIC FEET)
L1 UPPER	39" W x 53.5" H	12"	11
L1 LOWER	39" W x 53.5" H	24"	20
L2	49" W x 23.5" H	12"	11.9
L3 UPPER	39" W x 53.5" H	12"	9.9
L3 LOWER	39" W x 53.5" H	24"	17.9
R1 UPPER	39" W x 53.5" H	12"	11
R1 LOWER	39" W x 53.5" H	24"	20
R2	49" W x 23.5" H	12"	11.9
R3 UPPER	39" W x 53.5" H	12"	9.9
R3 LOWER	39" W x 53.5" H	24"	17.9
RR1	45.5" W x 24.5" H	22"	17.7
TOTAL			159.1

